



**SPECIFIC VEHICLE ALARM FITTING INSTRUCTIONS**

**REV. 00**

www.cobra.it

MAKE **MERCEDES** MOD. **VITO** YEAR **04** → PETROL  DIESEL

<b>ALARM/SIREN POSITION</b>	Position the compact alarms and the sirens on the support of the shock absorber, driver's side. Pass the cables using the original fairlead located in the bulkhead that divides the engine compartment and the passenger's compartment, above the driver's side shock absorber.
<b>CENTRAL UNIT POSITION</b>	Position the modular systems and the modules under the dashboard, driver's side.
<b>POWER SUPPLY</b>	<b>+30:</b> connect to the 4 mm <sup>2</sup> RED wire located in the general supply wiring harness, in the fuse box. <b>-31:</b> connect with a cable terminal directly to the ground terminal located behind the driver's side sill cover.
<b>IGNITION WIRE</b>	<b>+15/54:</b> connect to the BLACK wire in the 18 way connector marked A 125, located behind the fuse box.
<b>DIRECTION INDICATORS</b>	Connect to the BLACK/GREEN and BLACK/WHITE wires located in the 18 way connector marked A 125 located behind the fuse box.
<b>ELECTRIC WINDOWS</b>	<b>Positive control signal</b> <b>Front window, driver's side:</b> cut the BLACK wire directly on the coming out of the serial push-button. <b>Front window, passenger's side:</b> cut the WHITE/BLACK wire located in the wiring harness coming out of the driver's side door.
<b>CENTRAL DOORS LOCKING</b>	<b>Positive control signal</b> Refer to the <b>fitting diagram nr. 214.</b>
<b>IMMOBILISATION POINT</b>	<b>Gasoil pump</b> Cut the RED/BLACK wire in the wiring harness coming out of the fuse nr.24, under the driver's side seat . It is suggested an additional relay.
<b>STARTER</b>	<b>+50:</b> Cut the wire in the wiring harness on the side of the fuse box coming out of the ignition key.
<b>BONNET SWITCH</b>	Install an additional switch on the headlamp support plate.
<b>DOORS SWITCH</b>	For the anterior doors: connect to the BROWN/WHITE wire in the wiring harness coming out of the push-button of the driver's side anterior door and for the posterior doors: connect to the BROWN/BLUE wire in the wiring harness coming out of the push-button of the driver's side door.

**FITTING DIAGRAM NR. 214**

**Diagram to make the central locking on  
MERCEDES VITO year 2004**

**A section**

For 3100, 3900 and Cobra Connex antithefts

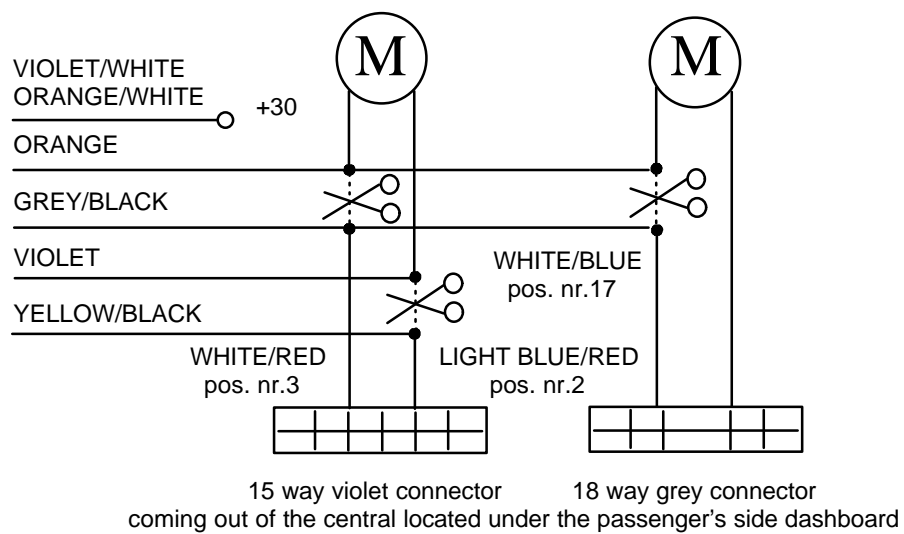

**B section**

For 7900 serie antithefts

